

L7_

O predisposizione del falso telaio su cartongesso

sub-frame arrangement on *drywall*

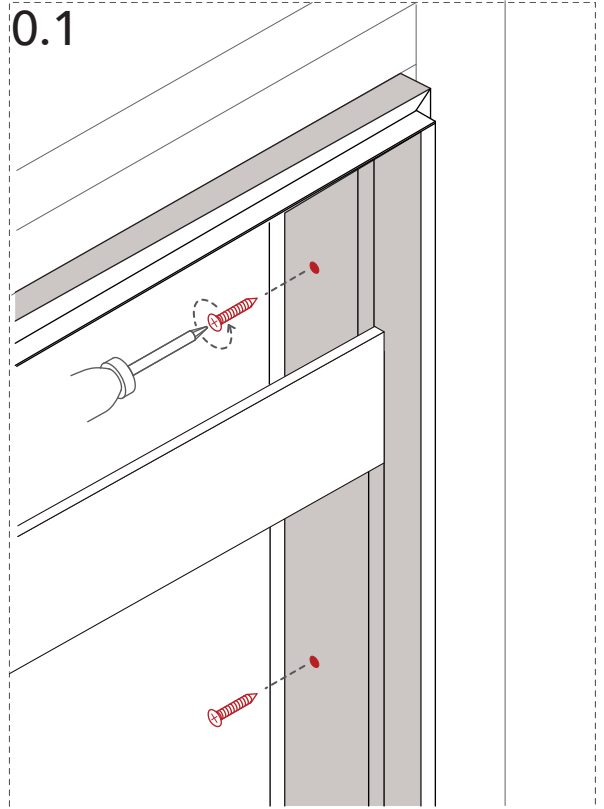
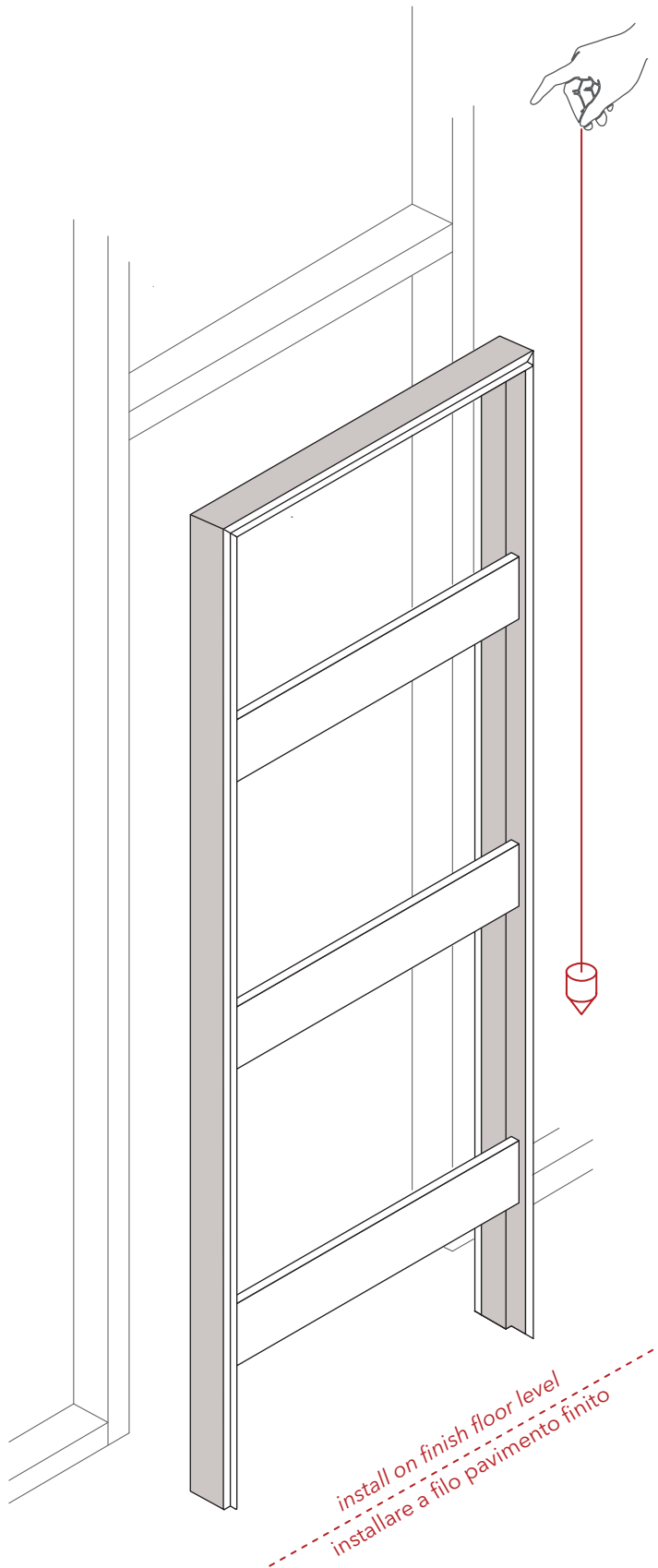

0.1
Fissare il falso telaio ai montanti con le viti.
Fix the subframe to drywall beams with screws.

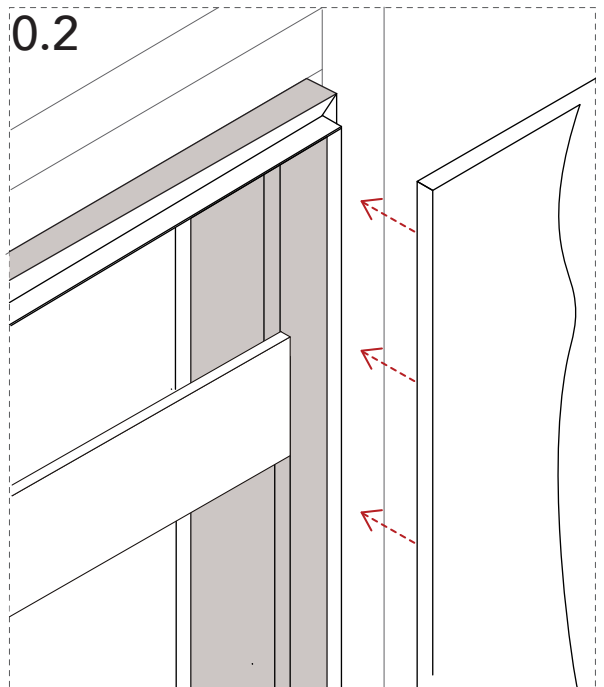

0.2
Allineare le lastre di cartongesso al profilo di metallo.
Align plasterboards with the metal bar.

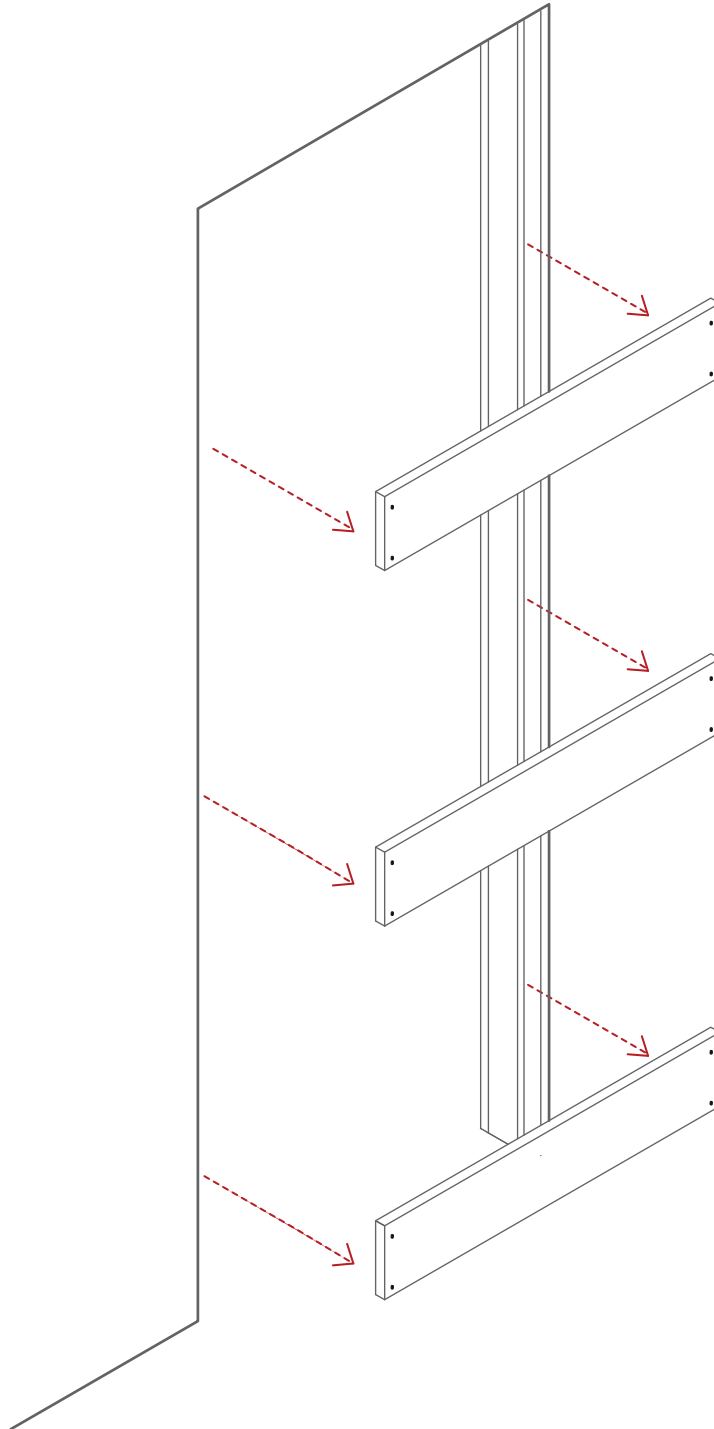
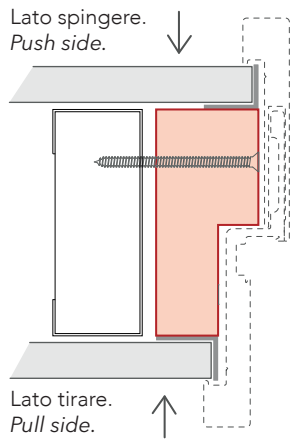

0.3

Rimuovere gli irrigidimenti solo dopo aver ultimato e verificato la corretta installazione del telaio.
Remove spacers only when the correct installation is verified

O predisposizione del falso telaio su muratura sub-frame arrangement on brickwall

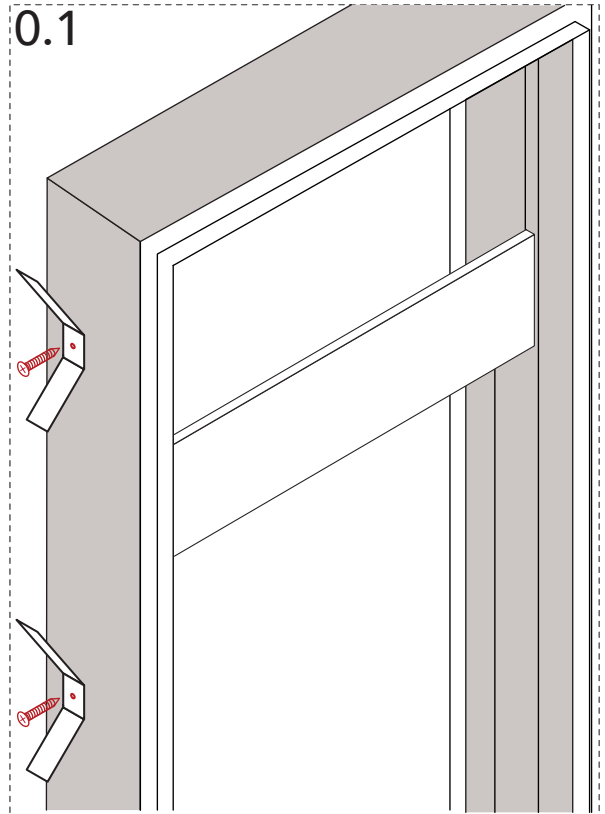
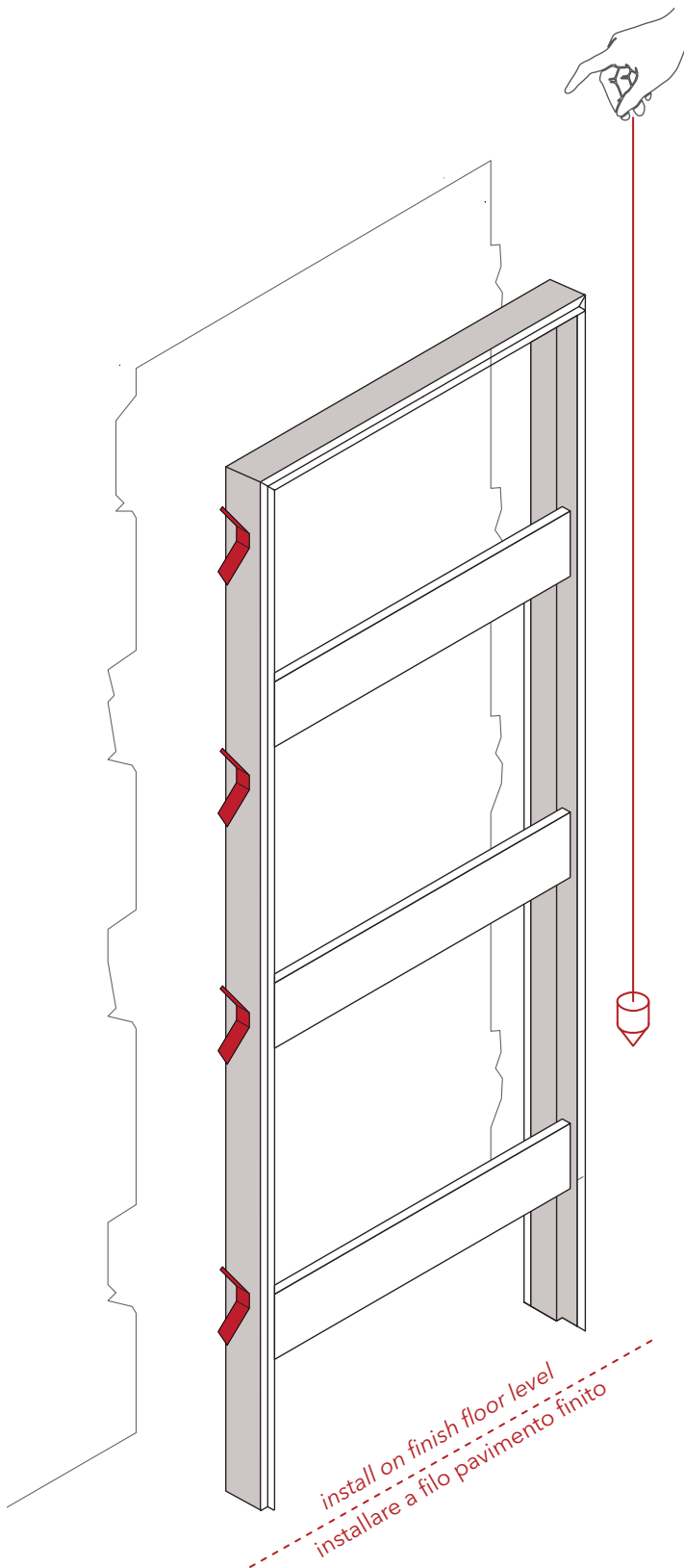

Fissare le zanche al falso telaio.
Set the brackets on the subframe.

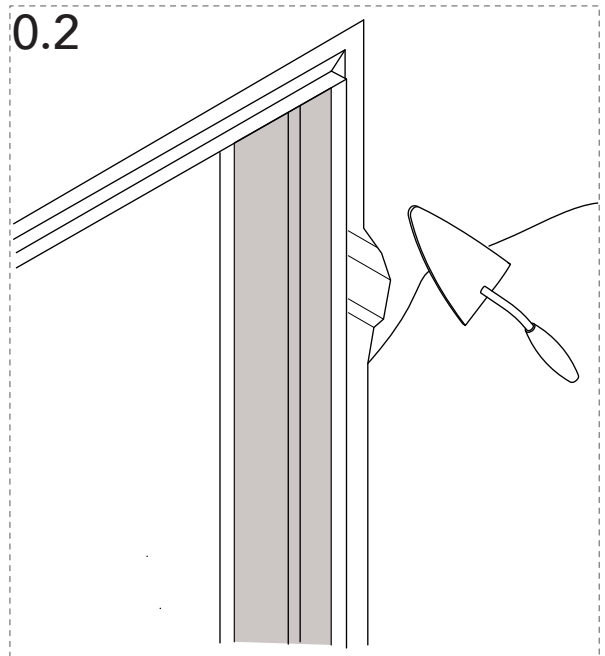

Cementare e rasare l'intonaco a filo del profilo di metallo.
Cement up and finish the plaster flush with the metal bar.

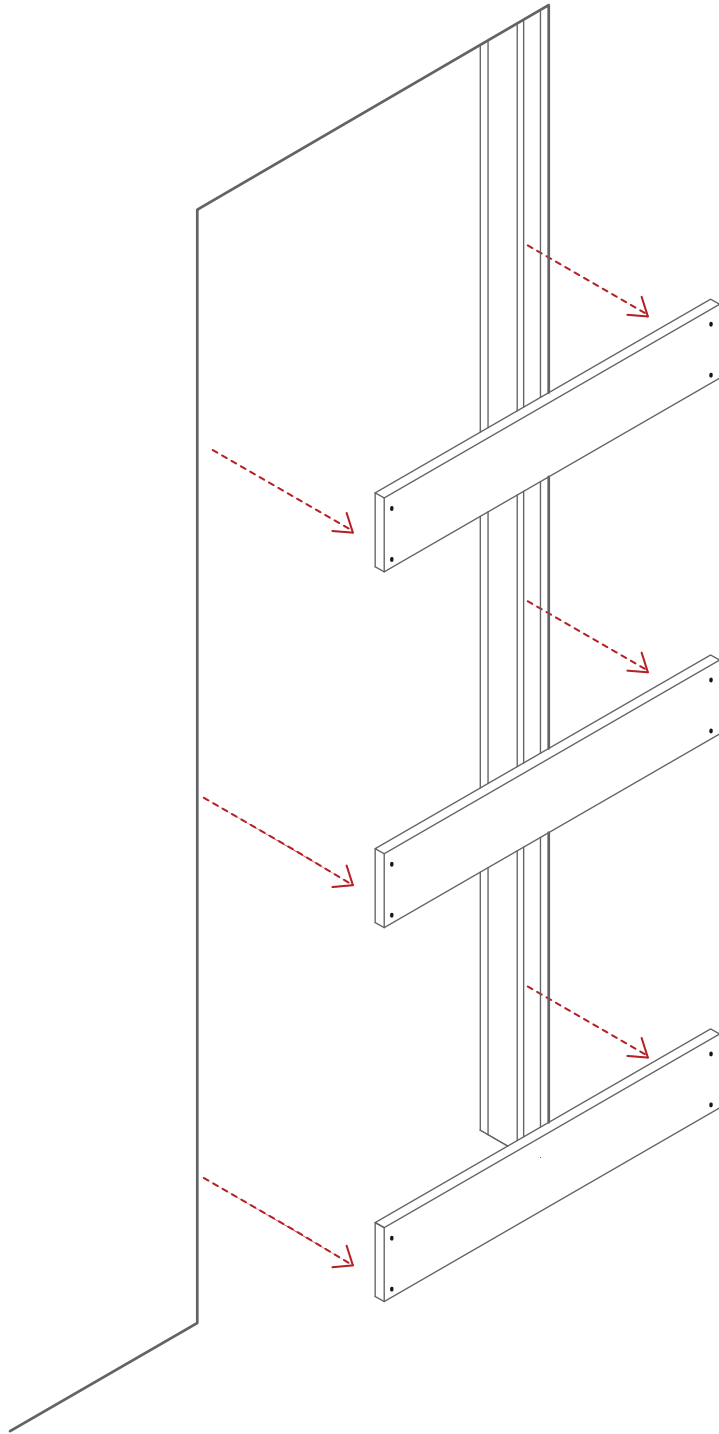
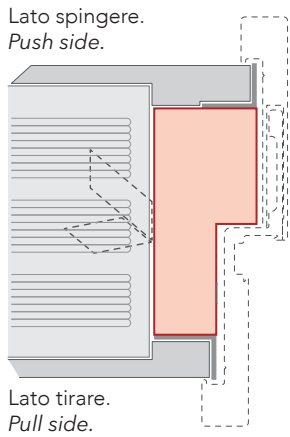

0.3

Rimuovere gli irrigidimenti solo dopo aver ultimato e verificato la corretta installazione del telaio.
Remove spacers only when the correct installation is verified

1 assemblaggio stipite jamb assembly

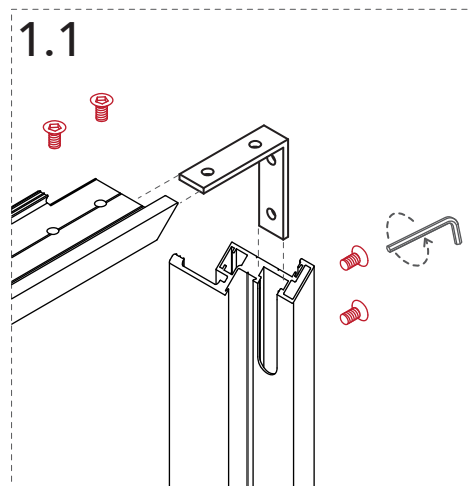
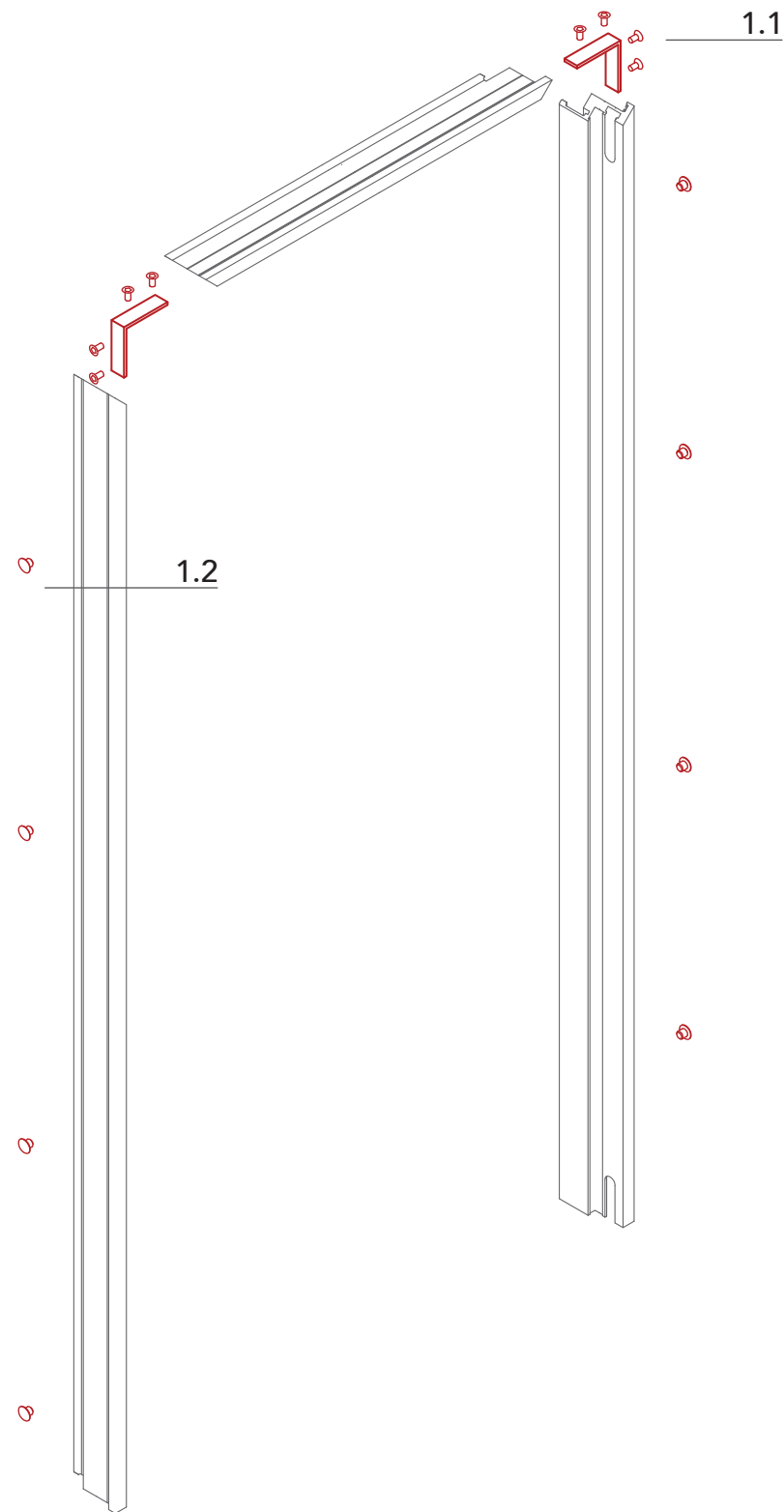

Unire lo stipite con le squadrette e le viti.
Connect the jamb, angle brackets and screws.

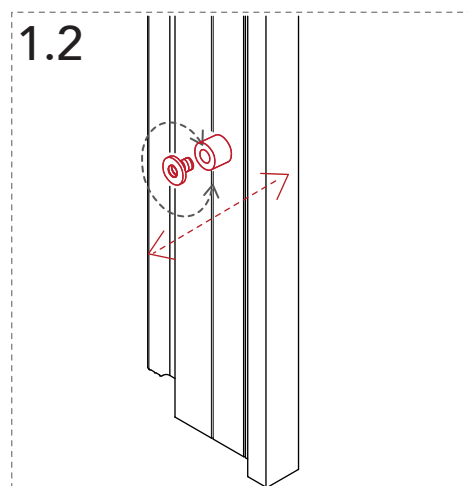

Inserire e regolare le boccole.
Put and adjust the bushing in the jamb.

2 montaggio dello stipite jamb finzing

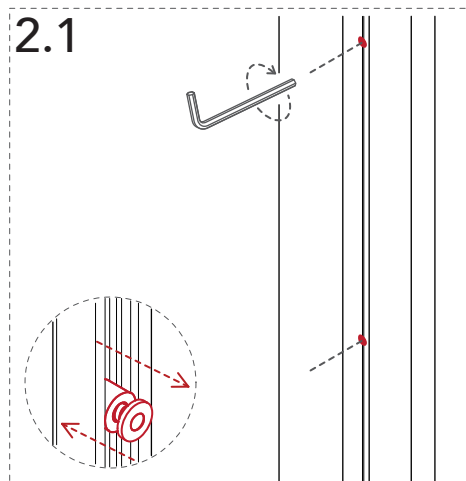
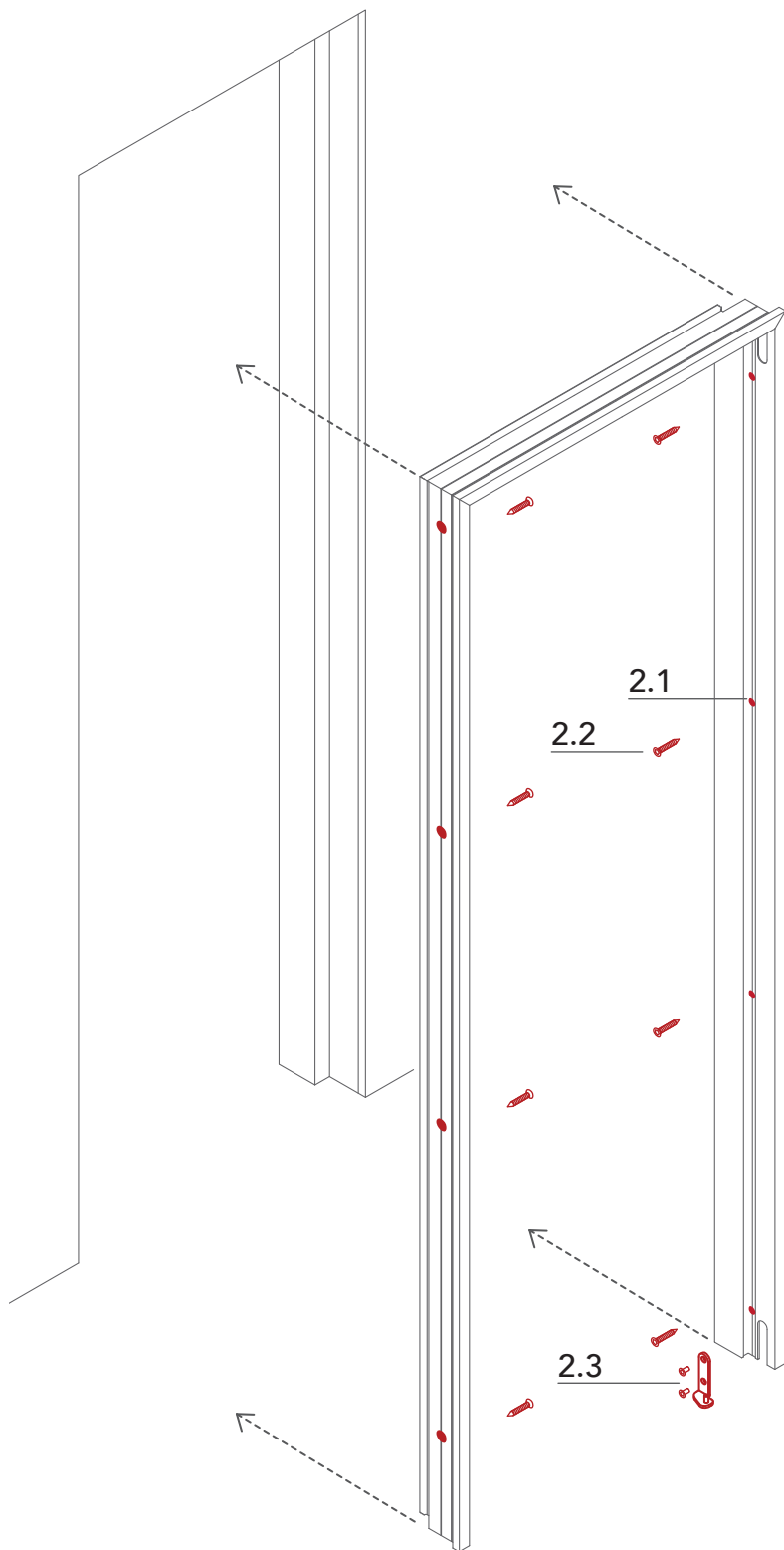

2.1
Regolare le boccole prima di fissare lo stipite.
Adjust the bushing before jamb fixing.

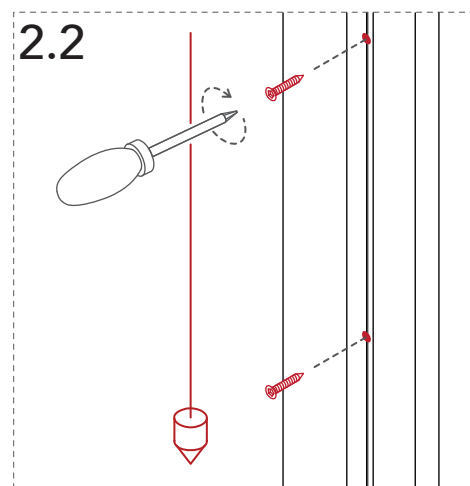

2.2
Fissare lo stipite verificandone la planarità.
Fix the jamb and verify the alignment.

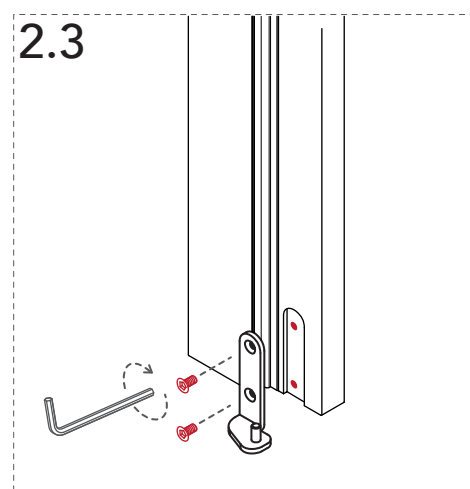

2.3
Fissare la cerniera inferiore con le viti.
Screw the lower hinge to the jamb.

3 montaggio dell'anta *door panel assembly*

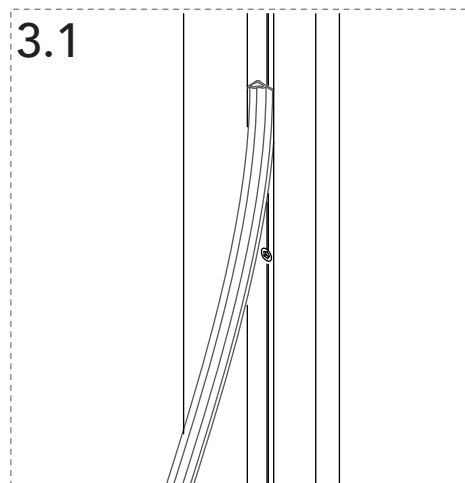
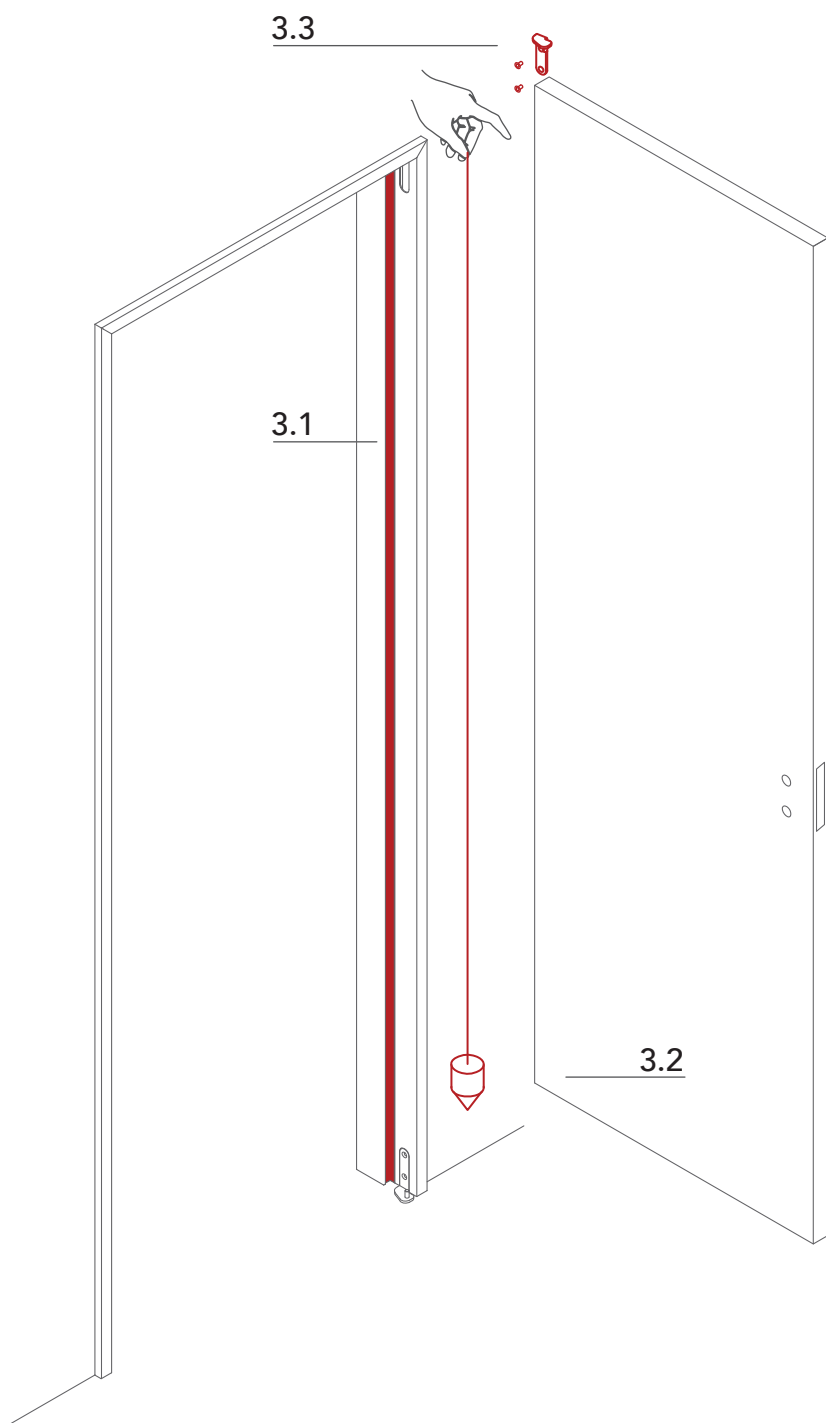

3.1
Inserire la guarnizione.
Insert the gasket.

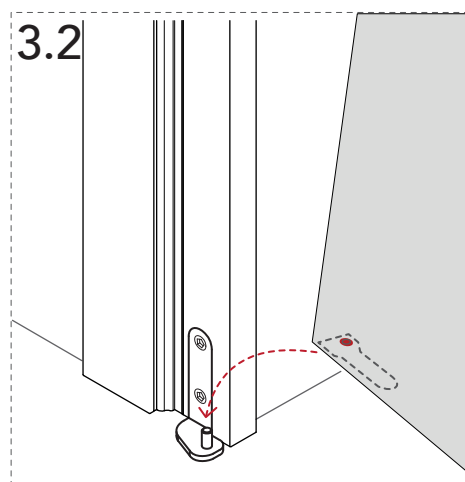

3.2
Posizionare l'anta sulla cerniera inferiore.
Set the door panel on the lower hinge.

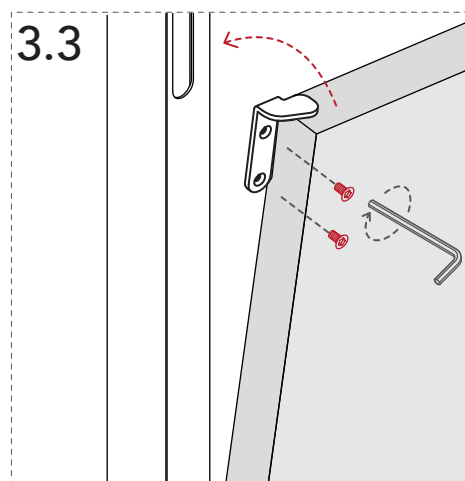

3.3
Infilare la cerniera superiore nell'anta e avvitare.
Insert the upper hinge in the panel and screw.

4

assemblaggio del coprifilo
door trims assembly

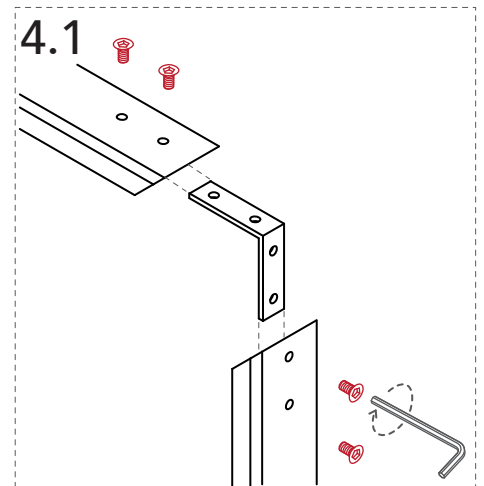
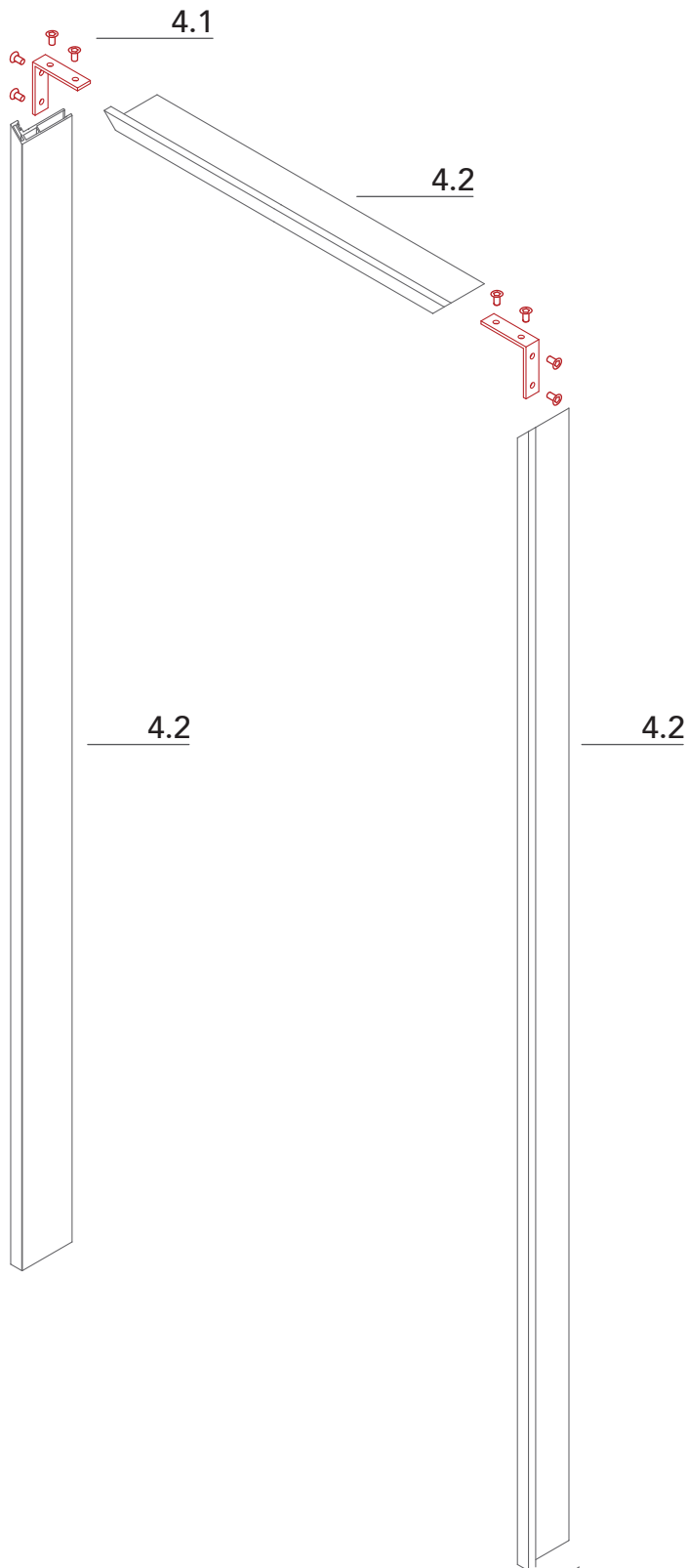

Unire il coprifilo con le squadrette e le viti.
Connect the door trim, angle brackets and screws.

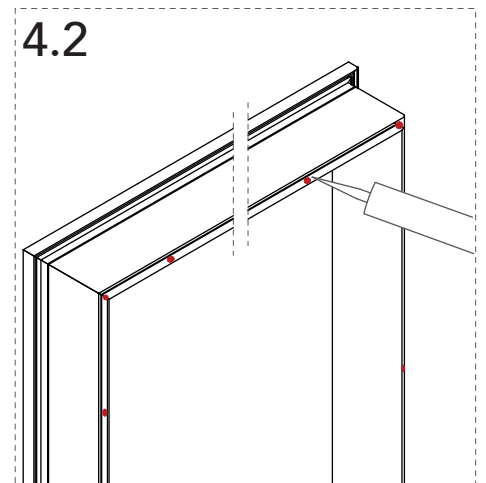

Inserire dei punti di silicone.
Apply the silicone in small spots.

5 montaggio del coprifilo door trims installation

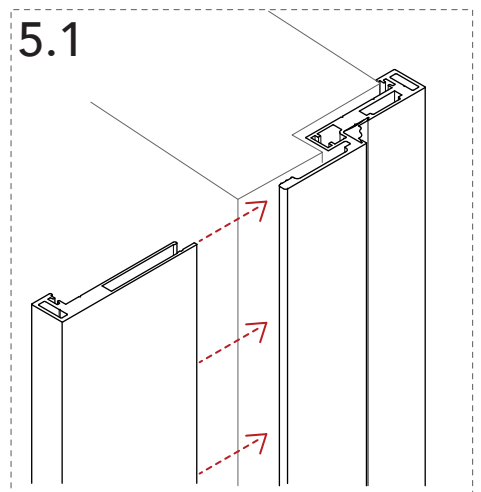
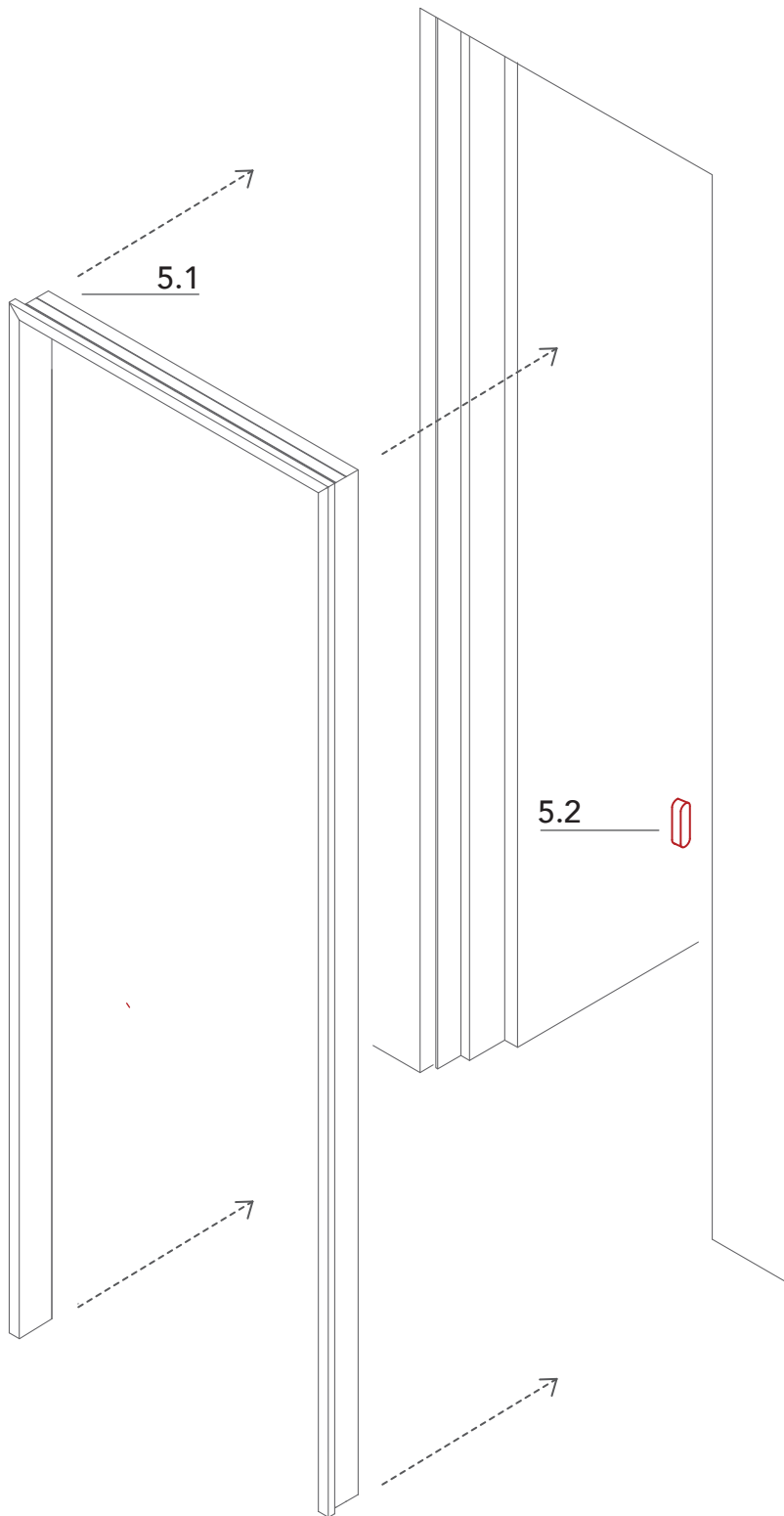

Unire il coprifilo allo stipite.
Join the trims to the jamb.

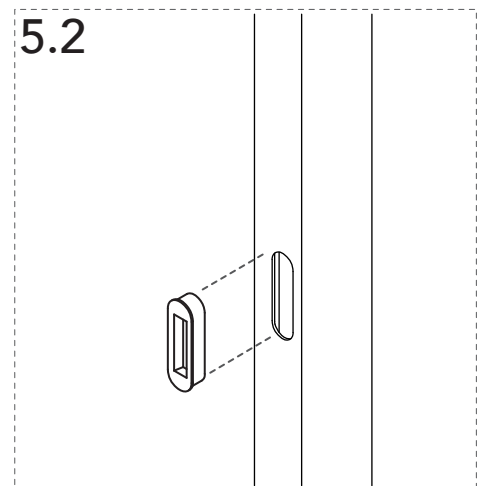

Inserire le bocchetta magnetica.
Insert the magnetic strike.

6 montaggio della maniglia handle installation

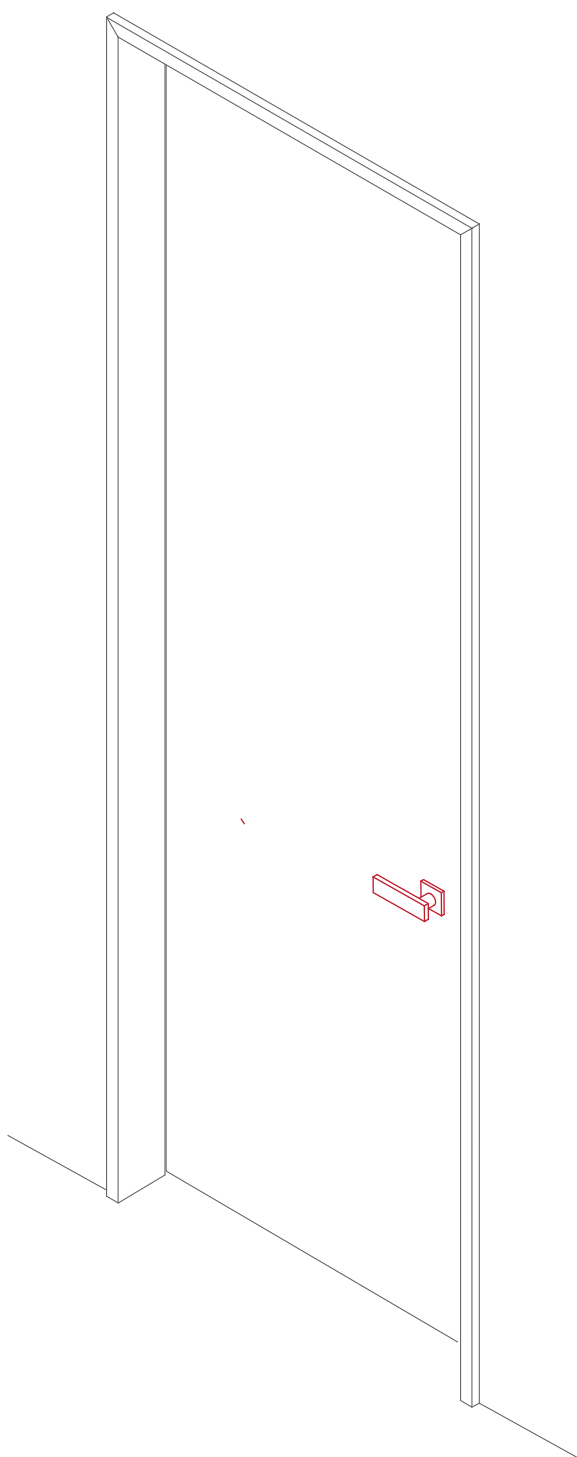

6.2 - ANTA LEGNO / WOOD DOOR



Forare l'anta prima di avvitare la sottoresetta.
Predrill the panel before screw the handle support.

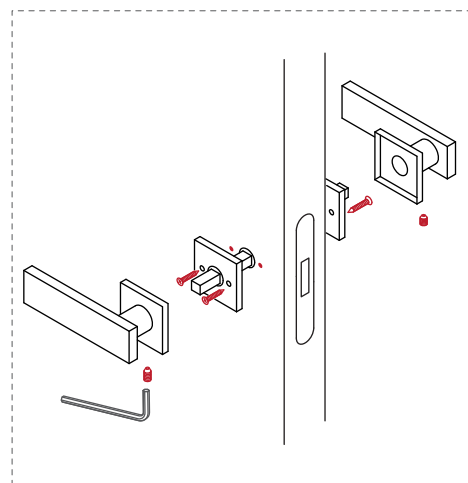

6.2 - ANTA VETRO L7 / GLASS DOOR L7

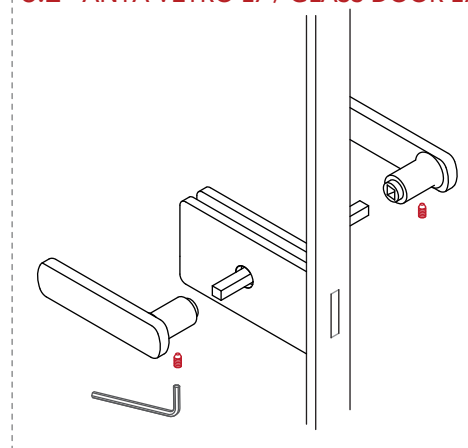

Lualdi S.p.A.

via Kennedy
20010 Marcallo con Casone (Milano)
tel. +39.02.9789248
fax +39.02.97289463
www.lualdi.com
info@lualdi.com

showroom:

Milano

foro Buonaparte, 74
20121 Milano
tel. +39.02.8052445
fax +39.02.8052251
showroom@lualdi.com

Miami

2311 North Miami Avenue
Miami Florida 33127- 4431
Tel. +1.305.4615464
Fax +1.305.4616426
infomiami@lualdi.us

New York

110 Greene Street
Suite 306
New York, NY 10012
Tel. +1.212.334.4544
Fax +1.212.334.4618
infony@lualdi.us